



The missing link between BPM and accounting

Using event data for accounting in process-oriented organizations

Christian Sonnenberg and Jan vom Brocke
*Institute of Information Systems, University of Liechtenstein,
Vaduz, Principality of Liechtenstein*

Missing link
between BPM
and accounting

213

Received 20 December 2012
Revised 27 June 2013
Accepted 27 June 2013

Abstract

Purpose – The purpose of this paper is to integrate business process management (BPM) and accounting on a conceptual level in order to account for the economic implications of process-state changes in process design-time and process run-time.

Design/methodology/approach – The paper adopts a design science research paradigm. The research, grounded in an “events” approach to accounting theory, builds on the REA accounting model that has been adapted for the design of a process accounting model (PAM).

Findings – The paper presents a PAM that can be used to structure event records in process-aware information systems (PAIS) to enable process-oriented accounting. The PAM is specified as a light weight data structure that is intended for the integration of PAIS and accounting information systems.

Research limitations/implications – As this paper is technical in nature, more research is needed to evaluate more thoroughly its approach in naturalistic settings.

Practical implications – The PAM can support traditional accounting approaches, and because of the adopted events approach, it readily supports use cases related to real-time analytics in BPM and accounting.

Originality/value – The PAM presents a novel approach to integrating BPM and accounting. The novelty of this approach lies in its use of event records to document flows of economic resources.

Keywords Accounting, Process performance, Activity-based costing, Event-driven BPM, Process analysis, Process simulation, Resource event agent, Process accounting model, Process mining, Process audit

Paper type Conceptual paper

1. Introduction

Many researchers have described the expectations and objectives that are associated with organizations’ adoption of business process management (BPM) in organizations. BPM is considered an important approach to the management of organizations since, to a large extent, organizational performance is built into its business processes (Balasubramanian and Gupta, 2005, p. 680). Once an organization has committed to adopting BPM, decision makers need accurate process performance data and metrics to make the right decisions about their processes (Harmon, 2011). Managers need to understand how, where, and when a business process creates economic value in order to decide which processes should be redesigned, improved, or eliminated. In particular, managers need to know “what is the contribution of business processes” (Yen, 2009, p. 866) in order to coordinate their BPM activities properly. Therefore, what is required in BPM are means by which to account for the creation of economic values in a process context.



The importance of accounting information in grounding BPM decisions notwithstanding, BPM researchers and practitioners have pointed out that decision making in BPM lacks an economic perspective (vom Brocke, 2007; vom Brocke *et al.*, 2010; Buhl *et al.*, 2011) stemming primarily from the absence of relevant, process-oriented accounting information in the context of planning, designing, and controlling business processes (Harmon, 2011; Müller-Wickop *et al.*, 2013).

Process-aware information systems (PAIS) (Dumas *et al.*, 2005), as main facilitators of BPM initiatives and central information sources for process managers, cannot readily provide relevant accounting data for decision support since, in many cases, PAIS are not well-integrated with an organization's accounting information systems (AIS) (vom Brocke *et al.*, 2011). The lack of process-related accounting data in PAIS is assumed to cause several dysfunctional effects in BPM decision making:

- *Existing methods for operational decision support in BPM are focused on technical and structural criteria.* vom Brocke *et al.* (2011), such as soundness of process specifications, process lead times, and the quality of process output. While PAIS account for such information, the economic consequences of letting processes (fail to) comply with these criteria cannot be disclosed or traced by contemporary PAIS.
- *Costs are the only accounting artefact frequently considered in BPM.* The processing times and frequency data that can be extracted from event logs suggest that cost calculations can be accomplished easily. However, the analytical apparatus for process cost calculations in BPM lacks solid grounding in accounting theory, resulting in cost calculations that draw on direct costing or oversimplified and misconstrued activity-based costing approaches.
- *Economic implications of individual process states are not accounted for.* PAIS create and capture vast amounts of business events, which are stored in event logs, transaction logs, data bases, or data warehouses (van der Aalst *et al.*, 2010). Tools that make use of these event logs, such as business activity monitoring (zur Mühlen and Shapiro, 2010) and process mining tools (van der Aalst *et al.*, 2010), give decision makers insights into the structural properties of processes and process instance behaviour like processing times, frequent process paths, and shadow processes. However, these tools currently cannot account for the economic implications of individual process states. Accounting information, such as resource expenses, current inventory, resource consumption, current sales, and order volume on a value basis (€1.000 of product X per day, €30.000 product X per month, etc.), is usually not readily available in PAIS, making it difficult for process managers to conduct sound economic analyses (Harmon, 2011). Besides the work presented in this paper, only one other study has addressed the challenge of integrating cost accounting data in event logs produced by PAIS (Wynn *et al.*, 2013). However, in contrast to the work presented in our paper, their work is limited to a cost perspective.
- *Economic reciprocity is not explicitly accounted for in process design and process control.* Processes create not only costs but also income, revenue, payment receipts, receipts of goods, and so on. Moreover, established process definitions that regard business processes as a sequence of activities creating value for the customer (Davenport, 1993; Hammer, 1993) may imply an overall unbalanced

approach to process evaluations, as these definitions address only the customer perspective (Ramsay, 2005). While satisfying customer needs surely must be a central concern in BPM, first business processes must serve the economic interests of the organizations that own them. Therefore, BPM has to account for both “giving” and “taking” in the design, execution, and control of business processes.

- *Strategic decisions in BPM are often taken based on subjective plausibility considerations* (vom Brocke *et al.*, 2010). Again, this issue may be attributed to the absence of accounting data in event or transaction logs, which prevents managers from drawing conclusions about economic consequences from business-event data. Van der Aalst *et al.* (2010) point out that, despite supporting process executions, even large-scaled PAIS (like ERP systems) may not be process-oriented from a data perspective, as the data related to a particular process is not accessible from a central data source but is, instead, distributed over multiple tables without direct reference to the processes to which they belong (van der Aalst *et al.*, 2010). This problem is particularly prevalent with accounting data stored in ERP systems. Accounting data in ERP systems contains few, if any, references to the process instances that create or manipulate accounting data (vom Brocke *et al.*, 2011; Müller-Wickop *et al.*, 2013).

AIS, on the other hand, afford a wide range of methods to collect information about the economic value created by an organization. However, these methods tend to be process-unaware (McCarthy, 1982) and do not account for detailed control flow structures and process states. As a consequence, although accounting should provide decision makers with relevant information about economic activities, AIS are also generally unable to account for the economic implications of process designs or process states.

Ideally, process managers could use the information provided by both AIS and PAIS in order to obtain accounting information that is relevant to decision-making in BPM. However, none of the requisite info-logical or data-logical structures necessary to establish a dedicated process-oriented accounting have been proposed in the accounting or BPM literature.

It is the overall aim of this paper, then, to seek generalizations about the data to be handled in the context of process-oriented accounting. In particular, the paper proposes a process accounting model (PAM) that is expected to be capable of integrating and structuring accounting data and process data in support of the design, execution, and control of business processes.

The paper proceeds as follows: Section 2 elaborates on the research methodology followed in developing the PAM. Section 3 explores conceptual overlaps at the intersection of BPM and accounting and introduces the “events” approach to accounting theory, which was instrumental in the design of the PAM. Section 4 defines key concepts at the intersection of BPM and accounting and merges both perspectives on a conceptual level. Section 5 presents the PAM, which is based on the definitions provided in Section 4, while Section 6 sketches out exemplary case scenarios for using the PAM. The paper concludes with an outlook on future research in Section 7.

2. Research methodology

The PAM was developed according to a design science research (DSR) approach (March and Smith, 1995; Hevner *et al.*, 2004). Choosing a DSR approach is justified,

as DSR is fundamentally a business-problem-solving paradigm that creates prescriptive knowledge in the form of novel IT artefacts (Hevner *et al.*, 2004). The business problem addressed in this paper is the problem of accounting for the economic consequences of business process designs and running business process instances. The artefact to be developed is a generalized data structure for event logs of PAIS that seamlessly integrates with an organization's AIS.

Truth statements in DSR ultimately centre on the "utility" of an artefact to solve a business problem. Therefore, established DSR methodologies position artefact evaluations at the end of a DSR process (Peppers *et al.*, 2007) in order to demonstrate an artefact's utility in a real setting. These evaluations often reveal that artefacts are either not readily useable in practice or are so ill-specified as to require subsequent design iterations. Inferring the truth of an artefact specification late in a DSR project increases the risk of discovering a shortcoming too late in the project and increasing the length of iteration cycles (Sonnenberg and vom Brocke). Long iteration cycles can be costly in terms of development time, stakeholder buy-in, and the opportunity cost of solving a business problem too late.

It is preferable to ensure early in a DSR project that the anticipated design solution converges to an artefact that is technically sound, applicable, and (potentially) useful (Sonnenberg and vom Brocke, 2012). In this regard, Venable *et al.* (2012) suggest having multiple evaluation episodes within a DSR project in order to evaluate an IT artefact even before it is actually instantiated or applied in practice (a so-called *ex ante* evaluation). Following the idea of conducting multiple evaluations at different stages in a DSR process, Sonnenberg and vom Brocke (2012) proposed conducting evaluation activities after each major DSR activity (Figure 1). Their DSR process contains four generic evaluation episodes, with each episode focusing on different aspects of an IT artefact: artefact justification (relevance, suitability) (EVAL1), consistency of artefact design and applicability (EVAL2), ability to be instantiated (applicability) (EVAL3), and usefulness in practice (EVAL4).

Reporting on the results of each evaluation episode justifies a self-contained DSR publication on which other researchers can build (Sonnenberg and vom Brocke, 2012). For example, one publication could communicate the relevance of an artefact,

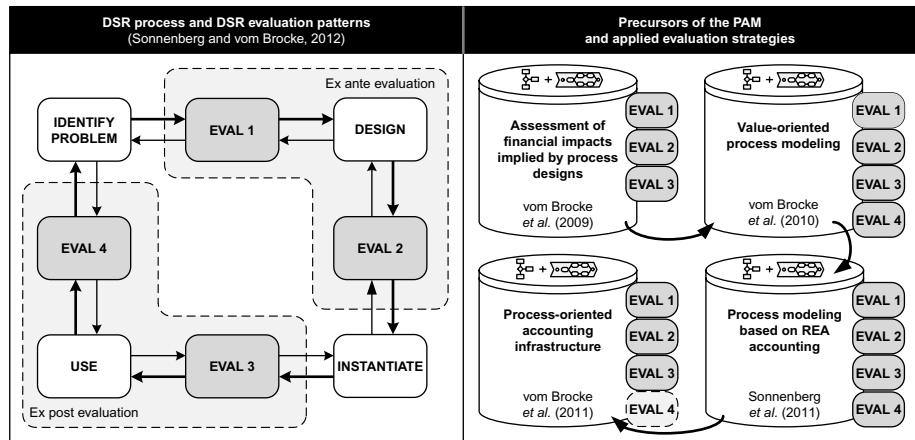

Figure 1.
DSR evaluation patterns
and evolution of the PAM

along with design requirements (EVAL1) that have been derived from an extensive literature review, expert interviews, surveys, etc. Another example is one publication to present in detail an artefact's design specification that is formally correct and applicable to the business problem addressed by the DSR project.

This paper reports in detail on the results of EVAL2 and EVAL3 activities conducted for the PAM. In particular, the core design specification and its underlying design principles are justified and explained in detail. Moreover, the design specification is articulated in terms of a formal language that has a long track record in data base design, the entity-relationship modelling method and diagramming technique (Chen, 1976), which is appropriate since we are seeking generalizations about data structures. The design specification itself is informed by the "events" approach to accounting theory (Sorter, 1969); Sections 3 and 4 provide an in-depth justification for our design decisions regarding the PAM design. Throughout this paper, we also demonstrate (EVAL3) how the PAM could be applied in practice in order to establish the potential applicability and usefulness of the PAM. The question of usefulness in particular is addressed by discussing case scenarios in Section 6.

The PAM evolved from a larger DSR process that began in 2009. The current PAM design decisions are also based on an evaluation of precursor artefacts that were presented in four earlier publications (vom Brocke *et al.*, 2009, 2010, 2011; Sonnenberg *et al.*, 2011), each of which addressed at least the first three evaluation activities of the DSR process shown in Figure 1.

Our research on the PAM began with a proposal for a data structure that links financial parameters to process descriptions in order to assess a business process' financial impact. We extended this approach in the second publication and applied it in the context of two case studies. A central outcome of the EVAL4 activity in the second publication was the insight that assessing financial impacts of process structures requires decision makers to specify many (financial) parameters manually, which negatively impacted the applicability and economic feasibility of the proposed assessment approach. Therefore, we opted for a solution that would afford at least a semi-automatic parameterization and provision of the data needed for financial assessments. Therefore, the third publication explored the possibility of explicitly incorporating an accounting perspective into business process models. The core artefact of this study was a domain-specific process-modelling language that was prototypically implemented in a process-modelling tool (accessible at: www.uni.li/bpatool) and applied in practice. The work in the third publication pointed us to conceptual overlaps of PAIS and AIS data structures that could be exploited for process-oriented accounting. The fourth publication elaborated upon this idea and formally specified it by means of an information model for process-oriented accounting. The specification was also instantiated into a Microsoft Access[®] prototype and applied in practice. The practical applications of this prototype directly informed the design of the PAM presented in this paper.

The PAM differs from its precursor artefacts in that its specification has been significantly extended to incorporate design principles that have been only implicitly considered in prior PAM publications. The explication and justification of the design principles underlying the PAM positively affect its generalizability. In terms of DSR, these design principles contribute to theorizing about a design artefact (Sonnenberg and vom Brocke, 2012). Such theorizing on the PAM was not attempted in our previous work.

3. Theoretical background

3.1 *Conceptual overlaps at the intersection of BPM and accounting*

The BPM and accounting domains share a set of key concepts. While accountants refer to business processes, activities, tasks, transactions, and events in the context of identifying, measuring, and communicating economic information “intended to be useful in making economic decisions” (AICPA, 1970, Statement No. 4, para. 9), the BPM domain refers to the same concepts to for the purpose of planning, implementing, and controlling how work is done in an organization.

While the BPM domain positions activities, tasks, and events on separate layers of abstraction when describing business processes, such a differentiated reference to abstract layers is not widespread in the accounting domain. Instead, accountants use the umbrella terms economic activity and economic event when referring to the concepts of events, activities, tasks, transactions, or even business processes. For accountants information about (high-level) process structures is relevant only for auditing purposes, while detailed accounts of process control flow structures are out of their scope, as accountants’ core task is the recording of economic events (Klamm and Weidenmier, 2004).

The diverging conceptualizations of business processes notwithstanding, the concept of events is central in both domains, where events are understood as phenomena that change the states of affairs that one wants to plan, monitor, and control. The centrality of events in BPM and accounting motivated us to centre the integration of the two domains on the concept of events, but this integration requires us to understand the role of events in either domain, as well as the nature of state changes disclosed by these events.

3.2 *The role of “events” and event data in BPM and accounting*

The identification and recording of event data serves various purposes, depending on what domain is considered. Accountants are interested in capturing and reporting economic events, as they impact an organization’s financial statements (Bagranoff *et al.*, 2012) or, more generally, its asset positions, so economic events are primarily recorded as part of an organization’s financial processes. However, economic events can also relate to changes in non-financial resources, so they may occur in any of an organization’s business processes.

Events in the context of BPM denote the occurrence of certain process-execution stages that are captured for the purpose of process coordination and control. These business events do not necessarily denote asset increases or decreases; they more generally denote changes in process states, so they represent non-financial information about past, present, and future process behaviour. Business events originate from the execution of business processes and are communicated through so-called event streams (Janiesch *et al.*, 2012) and event logs (van der Aalst and Weijters, 2005) created by PAIS (Dumas *et al.*, 2005).

Event records of either economic or business events are a potentially significant source from which to infer an organization’s past, present, and future course. Event logs are created by many types of PAIS, and they can also be reconstructed from various data sources (van der Aalst *et al.*, 2010). These event logs potentially contain references to both business and economic-event data, so the idea of linking AIS and PAIS based on a central event log is tempting.

Our approach proposes an event-log data structure that satisfies the information needs of both accountants and business process managers, so the challenge is to impose

a structure on event records that readily serves varying, even unanticipated, information needs that are pertinent to both the accounting and the BPM domains.

One strategy for such an event-log structure is to devise data structures that make as few assumptions about the potential uses of process and accounting data as possible. Such approaches have been proposed in the accounting domain under the term purpose-neutral accounting (Goetz, 1939; Schrader, 1962; Schmalenbach, 1948; Riebel, 1994), which has developed into what has been termed the “events” approach to accounting theory (Sorter, 1969; Johnson, 1970). The assertion that the “events” approach is capable of providing process-oriented evaluation structures (Geerts and McCarthy, 1999; McCarthy, 1982) has been put under scrutiny from a BPM perspective by vom Brocke *et al.* (2011), who found that the “events” approach to accounting is not necessarily process-oriented. However, they outlined potential interfaces between the “events” approach to accounting theory and BPM concepts that afford a process-oriented accounting infrastructure. This paper builds on this work and extends the conceptualization of interfaces between the “events” approach to accounting theory and BPM. The next section outlines the “events” approach to accounting theory adopted in this paper.

3.3 The “events” approach to accounting theory

Sorter (1969) proposed that the “events” approach to accounting theory as an alternative to traditional double-entry bookkeeping accounting, which is limited in its ability to support a wide variety of information needs and decision processes (Sorter, 1969). Traditional accounting suffers from several dysfunctional effects (McCarthy, 1982, p. 554):

- the one-dimensional nature of accounting data (only monetary measurements);
- the inappropriate classification schemes for data on economic affairs, which disregard non-accountants’ information needs;
- the excessively high aggregation level of stored accounting information, which prevents decision makers from accessing information according to their decision styles and underlying conceptual structures;
- the lack of integration with other functional areas, leading to inconsistencies, information gaps, and overlaps; and
- the inability to accommodate the process-oriented models of enterprises (Geerts and McCarthy, 1999, p. 1).

To overcome these dysfunctional effects multidimensional approaches to accounting have been proposed that incorporate the idea that accounting should provide disaggregated event data to ensure that the use of accounting data is not limited to only one application (Mauldin and Ruchala, 1999). Riebel (1994) referred to this characteristic as “purpose neutrality,” an idea that can be traced back to the work of Goetz (1939). Goetz (1939) proposed maintaining a “Basic Historic Record” to store primitive, raw data on occurrences, including the date of these occurrences, in order to keep track of what an organization has obtained or surrendered. Schrader (1962) built upon the work of Goetz (1939), and although unaware of the concept of business processes, hinted about the need to record accounting data in a process context, that is, to consider what happened, when it happened, where it happened and who was involved.

Sorter (1969) incorporated the ideas around purpose neutral-data recording into the “events” approach to accounting theory, suggesting that “the purpose of accounting

is to provide information about *relevant economic events* that might be *useful in a variety of possible decision models*" (Sorter, 1969, p. 13, emphasis added). Johnson (1970) later refined Sorter's approach into a normative events theory of accounting, pointing out that the monetary characteristic of many events could be the most relevant attribute in reporting a firm's past economic progress and forecasting its future economic course but that other characteristics may also be relevant for other events.

Implementing an "events" approach to accounting requires effective event-classification schemes and an event-based accounting infrastructure underlying an AIS (Riahi-Belkaoui, 2004). The resource event agent (REA) model (McCarthy, 1982) provides patterns according to which event-based accounting infrastructures can be structured and accommodates a process-oriented view of an enterprise (Geerts and McCarthy, 1999; O'Leary, 2004). Therefore, the REA model serves as a reasonable starting point for designing a PAM. A first attempt to link accounting and BPM based on the REA model was reported in vom Brocke *et al.* (2011), although this work only partly explored the limitations and potentials of REA in informing a PAM. Since the REA model is instrumental to the purpose of this paper, it is presented in the next section, before we introduce the PAM.

3.4 The REA model

The REA accounting model, which was first proposed by McCarthy (1982), has evolved into a domain ontology (Gailly *et al.*, 2008; Geerts and McCarthy, 2002, 2006). An extended excerpt from the REA domain ontology is shown in Figure 2 as a UML class diagram (OMG-UML, 2012). The REA model centres on the structuring of economic events in operational, planning, and policy layers.

The operational layer contains the basic REA model, representing a stereotypical economic exchange (Geerts and McCarthy, 2002). An exchange is executed between participating economic agents that act either as providers or as receivers of economic resources. Economic resources are scarce and have utility, so they are of value to economic agents (McCarthy, 1982). The scarcity and utility of economic resources motivates their exchange between agents; an agent usually gives up control of a resource to another agent in order to gain control over some other resource that is of greater value to the agent. Economic events denote "changes in scarce means resulting from

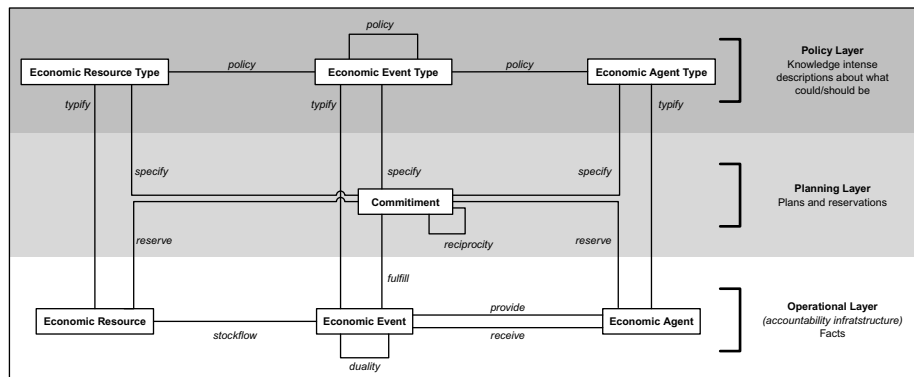

Figure 2.
REA ontology concept
specifications at the
business process level

Source: Synthesized from Gailly *et al.* (2008, p. 243) and Geerts and McCarthy (2006, p. 39)

production, exchange, consumption, and distribution” (McCarthy, 1982, p. 562), so economic events affect the availability and ownership of resources. A central concept in the REA ontology is the duality relationship between economic events. This relationship conceptualizes the principle of economic reciprocity, which holds that any economic event that affects an outflow should be compensated (i.e. be paired in duality) with an economic event that affects an inflow, and vice versa. For example, a purchase at an online shop includes the payment of cash (event denoting a resource outflow) and the receipt of the product ordered (event denoting a resource inflow).

The policy layer of the REA ontology is a mirror image of the operational layer (Geerts and McCarthy, 2006) that contains type descriptions of economic resources, events, and agents. On this layer, policy relationships between types document what should or could happen in the future.

The planning layer captures economic commitments about what should happen in the future. An economic commitment is a promise to perform economic events at some time in the future, so an economic event fulfills a commitment. Like economic events, economic commitments must be paired in duality to satisfy the economic reciprocity principle. A commitment can specify the type of economic event that fulfills it, the type of agent that performs the event, the resource type affected, and identifiable instances of agents or resources to be obtained or sacrificed in the future. Such a specification is realized through reservation relationships. In the example of the purchase from an online shop, two commitments are made: one to pay for an order and another to ship the product ordered.

Although the REA model is said to accommodate a process-oriented view of an enterprise (Geerts and McCarthy, 1999), it actually supports a high-level view of business processes (vom Brocke *et al.*, 2011). A business process in REA terms consists of linking economic resource flows. For example, a production process can be described on a high level as:

- obtain raw materials (an event denoting an inflow of raw materials) in return for paying cash (an event denoting an outflow of cash);
- consume raw materials (a decrease in raw materials) and use machinery and workforce (a decrease in machine and workforce capacity) to produce a good (an increase in the stock of produced goods); and
- sell goods (a decrease in the stock of produced goods) in return for cash (cash inflow).

The REA process view leaves out the details of how the economic resource flow is actually enacted and coordinated, but business process managers need this information in order to execute processes and seek opportunities for operational improvements. Decision makers in BPM require both information about operational process states and information about the economic implications of process states and process designs. The next section links the process view of the “events” events approach to accounting theory (described in more detail in vom Brocke *et al.*, 2011) with the BPM perspective. This conceptualization is then incorporated into the design of the PAM in Section 5.

4. Merging BPM and accounting concepts

4.1 Business events and business activities

Figure 3 provides a graphical account of the semantics of events, business events, and business activities in the context of PAIS. The figure shows a timeline onto which

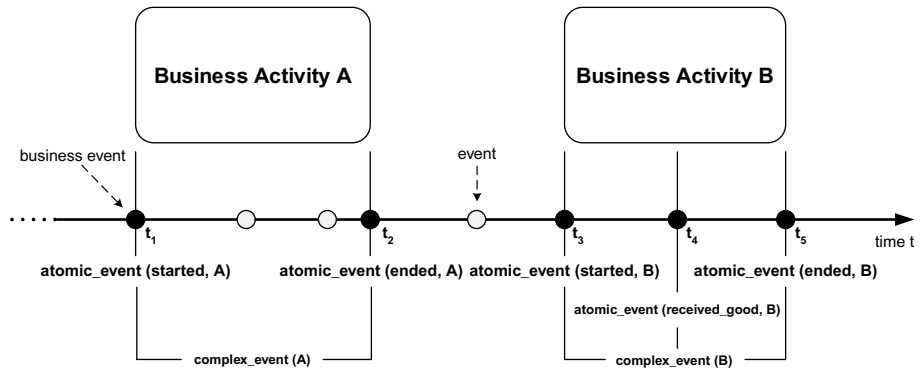

Figure 3.
Events, business events,
and business activities

the atomic event occurrences are mapped (circles). Atomic events may occur at any time point t_n , but not all events that occur in a particular time interval are perceived or recorded. Decision makers and system designers are often interested in perceiving and recording only certain atomic events (see events denoted as black circles in Figure 3), which are referred to as business events:

Def. 1. A business event denotes an event “that management wants to plan, monitor, and evaluate” (Denna *et al.*, 1993, p. 43). An observer perceives the occurrence of a business event as quasi-instantaneous, so business events have no duration.

PAIS typically “fire” business events at the start of a process instance, at the start of an activity, and at the completion, suspension, or abortion of activities. Such process or activity life-cycle events (van der Aalst, 2011) are of particular importance in coordinating and controlling workflows, so they are frequently recorded in event logs.

Business events are the materialized evidence that some purposeful business activity has been performed in an organization. Business activities may subsume many events. Business activities do not happen instantaneously but have a duration that can be most easily inferred from life-cycle events that denote the start and the termination of an activity. In practice, however, an activity instance may often be associated with only a single event occurrence (van der Aalst, 2011), making it impossible to infer activity durations readily from such business events in an event log.

Therefore, in some event logs events may have a “duration” attribute that indicates that an event occurrence represents an activity occurrence. Conceptually, these events are called complex events (Luckham, 2002) since they subsume the occurrence of lower events or event patterns (Decker *et al.*, 2007).

The events “complex_event(A)” and “complex_event(B)” (Figure 3) represent exemplary complex events that subsume lower-level business events. These complex events start at time point t_1 and t_3 , respectively, and have a duration:

Def. 2. A business activity denotes a collection of business events (complex business event) that management wants to plan, monitor, and evaluate as a whole. If there is only one business event occurrence associated with a business activity (instance), that business activity can be represented in an event log as a complex event that has a “duration” attribute.

4.2 Defining economic events and economic activities

The distinction between atomic and complex event types cannot be readily applied to the concept of economic events. In the accounting domain an economic event is defined as “a class of phenomena which reflects changes in scarce means resulting from production, exchange, consumption, and distribution” (McCarthy, 1982, p. 562). The implication of this definition is that an economic event can be both atomic (e.g. the receipt of cash that changes the amount of cash available “instantaneously”) and complex (the execution of a business activity that results in a change in available working hours for the time of the activity’s execution). In fact, REA economic events have been classified as complex events as part of an ontological analysis (Guizzardi and Wagner, 2005), suggesting that economic events denote economic activities.

However, in order to be consistent with our distinction between atomic and complex events/activities we want economic events and economic activities as distinct concepts. In particular, we hold that an economic activity does not subsume multiple economic events:

Def. 3. An economic event is an event that denotes a change in the availability of economic resources under the control of some economic agent or organizational unit. An observer perceives the occurrence of an economic event as quasi-instantaneous, this is, economic events have no duration. Therefore, an economic event is a special business event that an organization wants to plan, monitor, and control for the purpose of accounting.

Def. 4. An economic activity denotes a collection of business events and at least one economic event. Therefore, an economic activity represents a special business activity that an organization wants to plan, monitor, and control for the purpose of accounting. If there is only one event occurrence, an economic event, associated with an economic activity (instance), an entry of that economic activity can be represented in an event log as a complex event that has a “duration” attribute.

For example, Figure 4 shows an economic activity that is represented as a complex economic event (“complex_event(A)”) denoting a decrease in the available resource units (working time) of an employee. The resource units are used over a time interval ($t_2 - t_1$) (duration). In a fictitious event log, there would only be one event entry pertaining to the activity instance “Economic Event A”, with the attribute “duration” given a value ($t_2 - t_1$). An alternative way to represent this activity in an event log is to record two business events denoting the start and end of the activity. Both events denote changes in a resource. (In this case the start event decreases the resource’s availability, and the end event increases it). The duration of the economic activity can be calculated by subtracting the timestamp of the start event from that of the end event.

4.3 Defining business processes

Having defined the key concepts of business events, business activities, economic events, and economic activities, we can define what we understand to be a business process.

A business process is a collection of business events. For planning purposes a business process is structured into “meaningful” subsets consisting of business events that are associated with individual business activities. An alternative way of representing business processes is through collections of complex business events

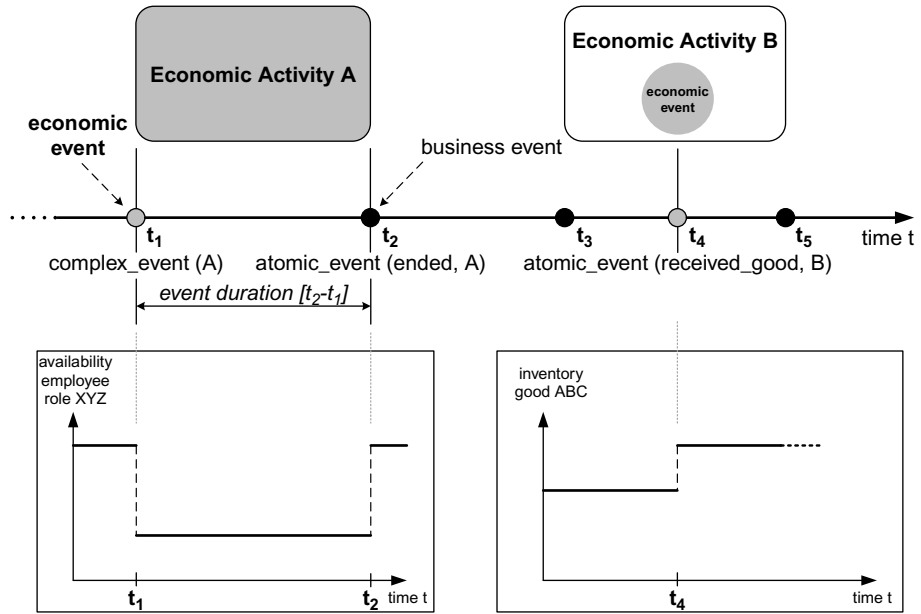

Figure 4. Economic events, economic activities, and changes in resource availability

or business activities together with atomic business events that represent the life-cycle of a process instance (like process start and end events).

A business process is executed for a business purpose that is reflected in the results (expected or achieved) of the business process. Therefore, a constituent characteristic of a business process is that it contains at least an economic event denoting the realization of a process result (i.e. an intended increase or decrease of a resource):

Def. 5. A business processes is a collection of business events (atomic or complex) that occur in the course of achieving a business process result. In order account at least partially for the process' economic rationale, a business process must contain at least one economic event denoting the achievement of the business process result (increase or decrease in a resource).

Figure 5 shows how the concepts of business events, economic events, and business processes relate to one another. The exemplary business process of receiving a good is described as a BPMN model (OMG-BPMN, 2012). The process model contains both atomic events (process and activity-life-cycle events) and complex events (activity definitions). The central result of the process is the receiving of a good (an increase in some resource). Every time this process is instantiated, a corresponding event stream is created by a PAIS that coordinates the process execution (see instances no. 1 to no. 3 in Figure 5). The economic implications of executing the process instances are plotted in diagrams that show how resource availabilities change over time as a result of changing process states.

4.4 Economic reciprocity and economic transactions

Our discussion so far has been based on the prevailing notion that a business process is a "system" (Melão and Pidd, 2000) that takes some input to produce an output that

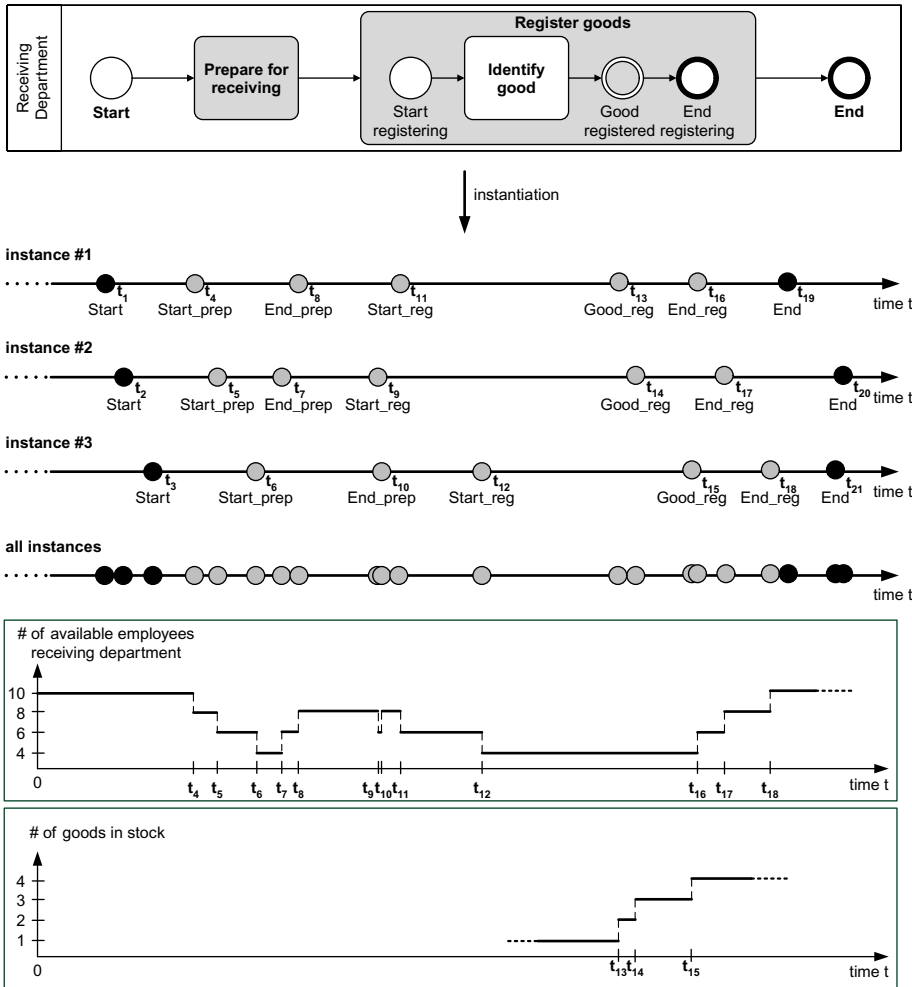

Figure 5.
Business process models,
event occurrences, and
economic implications

is of value to a customer (Davenport, 1993; Hammer, 1993). From an events perspective this notion implies a timely, logical sequence of receiving input from a supplier in t_1 , transforming this input into some output within the interval (t_2, t_3) , and then delivering this output to a customer at some time point t_4 (with $t_1 < t_2 < t_3 < t_4$) (Figure 6(a)). However, such a notion is too simplistic, as it ignores the fundamental principle that underlies almost all economic activities: economic reciprocity. Understanding business processes simply as transformative devices for serving customer needs does not do justice to the “business” part of the term “business process” and does not fully account for the economic rationale that underlies business process executions. Is it economically sensible to do business if only to satisfy customers?

Doing business involves economic exchanges in which one party to an exchange is willing to sacrifice resources under its control in order to acquire a valuable resource in

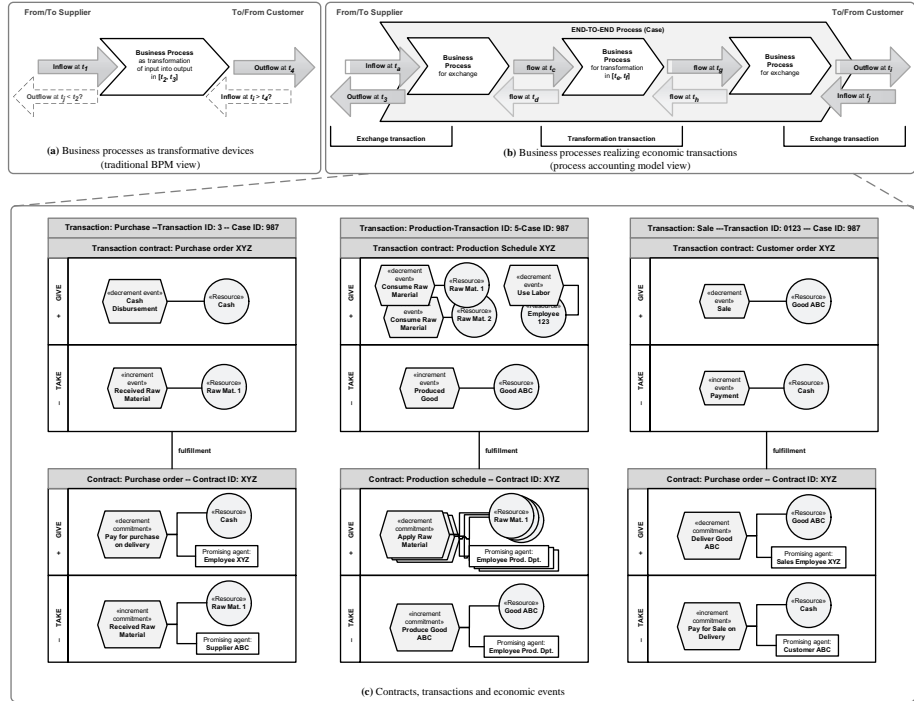

Figure 6. Patterns of economic reciprocity in BPM

return (McCarthy, 1982). Therefore, business processes may not be subject only to resource inflows from suppliers but also to inflows that originate from customers. Similarly, business processes may generate resource outflows directed not only towards customers but also towards suppliers.

It is the basic assumption of our PAM that a business process accomplishes two goals:

- (1) the use and consumption of economic resources to serve customer demands; and
- (2) the generation of economic resource inflows that serve the demands of other process stakeholders.

In short, business processes create value for both customers and other process stakeholders. This “give-and-take” pattern of economic reciprocity, which is only implicitly reflected in current approaches to business process modelling and analysis. The failure to consider economic reciprocity may eventually lead to descriptions of process architectures that are inconsistent, unbalanced, or even not feasible from an economic point of view.

Figure 6(b) extends the economic view on business processes by considering economic exchanges that enclose input-output-like transformations. Linking resource exchanges with resource transformations improves accounts of the economic rationales that underlie business processes, as economic exchanges usually entail other economic activities.

Exchanges and transformations are collectively referred to as transactions in this paper. All transactions have in common that they reflect the “give-and-take” principle (or, in REA terms, they are comprised of economic events that are paired in duality). Figure 6(c) shows a “sales” transaction as a partition between decrement (give) and increment (take) economic events (This notation was proposed in Sonnenberg *et al.*, 2011). In a “sales” transaction an organization transfers economic resources (e.g. a product in a sale event) to a customer and receives compensation (e.g. cash) from the customer in return (see customer payment event). The completion or balancing of a transaction does not depend on the timing of corresponding event occurrences, such as when a customer pays for an order in advance; what is important is simply that these events occur.

The events that are part of a transaction can occur within different business processes. For example, in the purchase transaction shown in Figure 6(c), a raw material might be received through an inbound logistics process, while the supplier invoice for this delivery might be settled by a cash-disbursement event that occurs as part of an organization’s financial processes. In order to correlate the economic events of different process instances (by means of a transaction), each event maintains a reference to the transaction instance with which it is associated. The identity of a transaction instance can be created based on the central contract that governs a transaction (e.g. a purchase transaction can be uniquely identified by the purchase order number, a sale transaction can be related to the customer order number, and a transformation transaction can be related to a production plan/schedule number).

A contract is the accounting artefacts that documents a demand, such as a customer’s demand through a customer order or an organization’s demand for supply of a good through a purchase order. Contracts are fulfilled by transactions. Contracts are comprised of commitments that are paired in duality; that is, a contract contains increment and decrement commitments (Figure 6(c)). A commitment is a promise of an economic agent to let an economic event occur at some point in the future (Geerts and McCarthy, 2006). An increment commitment is fulfilled by an increment economic event, and a decrement commitment is fulfilled by a decrement economic event.

Transactions themselves can also be correlated based on a case identifier derived from a central contract that governs all transactions. For example, in a repair process a broken tool might be received in an inbound transfer (transaction 1), be repaired (transaction 2), and be sent back to the customer (transaction 3). All transactions and thus all economic events of the end-to-end repair process relate to a repair order (contract). This repair order governs the planning and monitoring of the overall repair process, which is instantiated as a case that comprises multiple transactions (e.g. the receipt, repair, and delivery of a particular tool). Thus, a case establishes an end-to-end view on business processes:

- Def. 6.* A transaction is a set of related increment economic events and decrement economic events that fulfils a particular contract.
- Def. 7.* A contract is a set of related increment economic commitments and decrement economic commitments that specifies the demand of economic resources to be met by future economic event occurrences.
- Def. 8.* A case is comprised of one or more related transactions that together fulfil a central contract.

5. The PAM

5.1 The basic model and its principles of form and function

The PAM proposed in this paper adopts an “events” approach to accounting theory (Sorter, 1969; Johnson, 1970; McCarthy, 1982) and incorporates the definitions presented in Section 4. The PAM proposes four design principles that should guide the design of any event-accounting information system intended to be applied in a BPM context. These principles are:

- Principle of event-data disaggregation.
- Principle of event classification.
- Principle of process relatedness.
- Principle of economic reciprocity.

Figure 7 shows the basic constituents of the PAM by means of an entity relationship diagram (Chen, 1976). The PAM centres on the event concept and requires that events be planned (through the definition of event types) and that they can be perceived (event instances). Information about planned and perceived events should be documented in a central, purpose-neutral event record (disaggregation principle). Events in such an event log are further classified into business and economic events (classification principle). (Business) events happen in the course of executing business activities, so the event data is related to data about business activities (process-relatedness principle). The principle of economic reciprocity addresses correlations between economic events (see duality relationships between events and event types).

While the disaggregation, classification, and process-relatedness are already reflected in part by current PAIS, accounting for economic reciprocity is a novel element in the BPM domain. However, neglecting economic reciprocity could result in

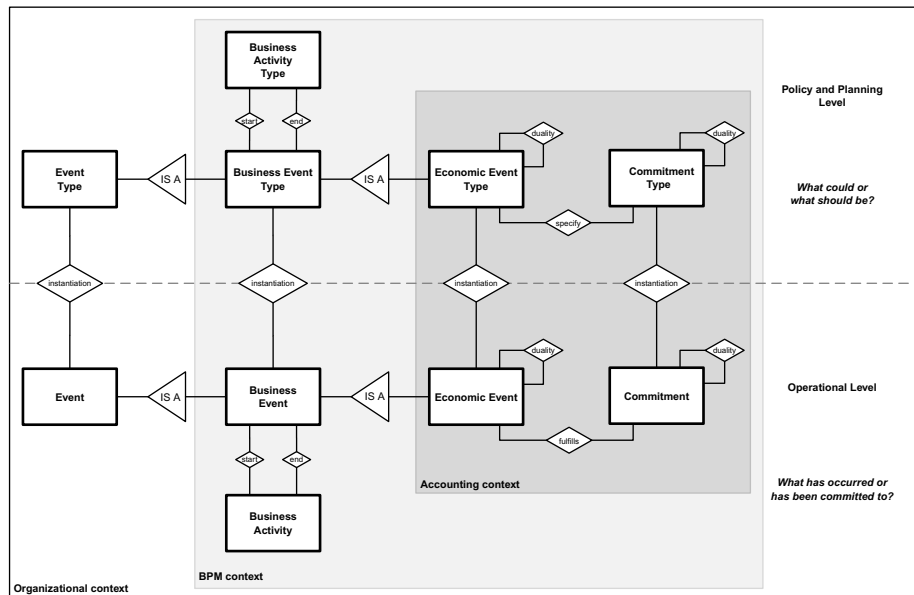

Figure 7.
The PAM

process designs that inappropriately account for economic interdependencies between business activities and business processes. Moreover, violations of economic reciprocity (like missing payments for a sold good) may not be detected easily in the context of current process monitoring approaches. By considering economic reciprocity, individual process states that are monitored on an operational level can also be evaluated with regard to their economic impact.

The next sections discuss the PAM principles in more detail and show how these principles can guide the derivation of data structures to enable process-oriented accounting.

5.2 Disaggregation principle

The disaggregation principle is directly derived from events accounting approaches (Goetz, 1939; Schrader, 1962; Sorter, 1969; McCarthy, 1982). The premise of events accounting is that event data are recorded in as disaggregated a form as possible. This premise accounts for the fact that event sources can be both inside and outside an organization and that each source may reflect a different perspective on organizational activities. In light of diverse event sources, disaggregation holds that event data are not persisted in a way that would favour particular interpretations that are pertinent to a dominant perspective. For example, if the only event type that is considered in an event record is data about accounting transactions, the event record can be interpreted only with regard to accounting phenomena. An event record that predominantly holds data that refers to activity and process executions (PAIS event logs) allows only that questions be answered about the structural properties of activities (e.g. start times, durations). Event records may also predominantly store fine-grained data about errors or manipulations of data objects that occur while using particular software applications. Interpretations would then relate to detailed, operational states of an organization on an application-system level.

In order to minimize interpretation bias in event records, the disaggregation principle of event data requires precise and consistent recording of all perceivable event occurrences in a single event record that preserves the information associated with an event in a general form (Schrader, 1962). Using an entity relationship-diagram, Figure 8 shows how the disaggregation principle can be realized in a PAM data structure. Event occurrences are stored in a table that contains a unique identifier for each

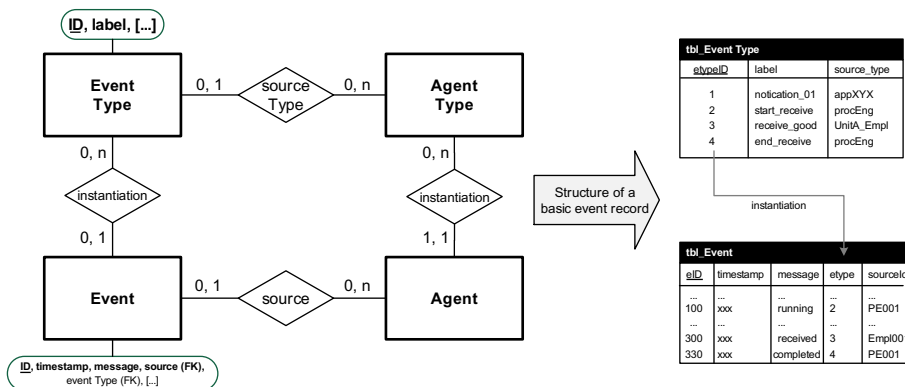

Figure 8.
Basic (purpose-neutral)
event record

event occurrence, a timestamp, an optional message (e.g. an error stack trace provided by a low-level system event), an optional source (the agent that caused the event), and an optional reference to a pre-defined event type. The definition of event types is not mandatory at this stage, but it is required for classifying and structuring business and economic events.

5.3 Event-classification principle

The event-classification principle requires that event types and event occurrences be classified in order to allow for multiple perspectives on an events record – in this case, a BPM and an accounting perspective. Figure 8 indicates the three event classes that are considered in PAM: unclassified events, business events, and economic events.

Figure 9 shows how event classes can be reflected in concrete data structures. Unclassified events can be specialized via a specialization relationship into business events (see the qualifier “IS A.”). The specialization implies that not every event is a business event, but every business event is an event and that not every business event is an economic event, but every economic event is a business event.

The mechanism according to which classification information is maintained in an events accounting database depends on the particular implementation strategy. In its simplest form each event class (business or economic) is represented by a separate table that can store class-specific properties. The event tables are linked through foreign keys. In Figure 9 the original, basic event table contains a foreign key for referencing records in the business events table. Similarly, the business-events table contains a foreign key that points to an economic-events table. Event-type definitions on the policy/planning level are persisted in an analogous table structure (not shown here).

What is classified as a business event depends on what event data a manager or domain expert perceives is relevant for planning, monitoring, and evaluating business activities. On the policy and planning levels a decision maker can define the business and economic event types that she or he wishes to be in a process model. Process models often contain explicit accounts of business-event types that are deemed relevant (see, e.g. event types in the BPMN). However, a means by which to classify and plan economic events is missing from process modelling languages. Only recently has a modelling approach been proposed that integrates economic event specifications into process models (Sonnenberg *et al.*, 2011).

We assume here that the application of the PAM requires that business and economic event types be defined and that these event types are observable at runtime or that they can be traced.

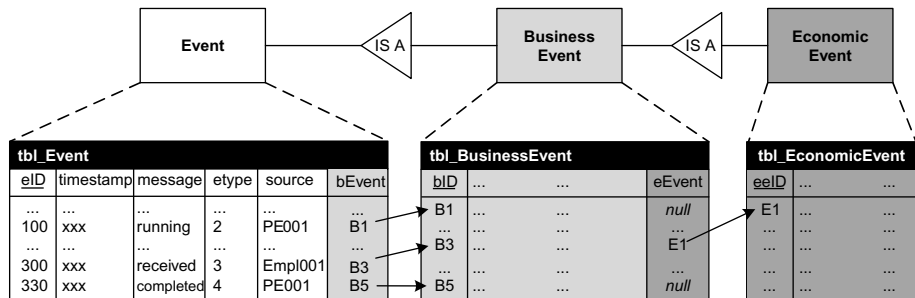

Figure 9. Event tables reflecting event classification on the operational level

5.4 Process-relatedness principle

The process-relatedness principle requires that business-event data refer to the process context in which a business event occurred or is planned to occur in order to facilitate reasoning about event dependencies that are determined by underlying process structures. PAIS usually store process-execution data in event logs (van der Aalst and Weijters, 2005), so they satisfy this principle. While the process-relatedness principle clearly pertains to the BPM domain, its relevance was also acknowledged in the accounting literature long before the advent of PAIS. This principle can be traced back to the antecedents of events accounting, particularly to the work of Schrader (1962). Although not aware of the concept of a business process, Schrader hinted about the need to record accounting data in a process context, suggesting that, for each relevant event, “consideration of accuracy in observation would require memoranda of *what* was exchanged [...] and possibly *when, where, and with whom* it was exchanged” (Schrader, 1962, p. 646, emphasis added). Enriching event data with contextual process data makes it possible to relate event-occurrence patterns to the process structures that govern the event occurrences.

Figure 10 extends the data structure presented in Figure 9 by introducing the entities “business process activity instance” and “business process instance” on the operational level and “business activity type” and “business process type” on the policy level. Business process types and business activity types can be specified in the context of process modelling, and then runtime occurrences of processes and activities can relate to these specifications. Each business activity instance implies at least one business-event occurrence (complex business event with duration). However, an activity can involve the occurrence of multiple business events, so each event that occurs in the context of a business activity has a reference to the related business activity instance.

The data model in Figure 10 also shows that, for every process, two separate business events must be defined and recorded to denote the start and end of a process. The attributes “isAEnd” and “isPEnd” (if set to “true”) signify that a business event denotes the end of an activity, a process instance, or both. The data structure shown in Figure 10 pertains to the operational layer, but the data structure on the policy layer (reflecting type definitions) is a mirror image of the data structure on the operational layer.

To populate the tables shown in Figure 10 with actual event data, business process managers and accountants import existing event streams from their organizations’ various event sources (zur Mühlen and Shapiro, 2010). Such imports can be facilitated by using event data exchange standards, which are frequently applied in the context of business-activity monitoring and process mining. The data structure shown in

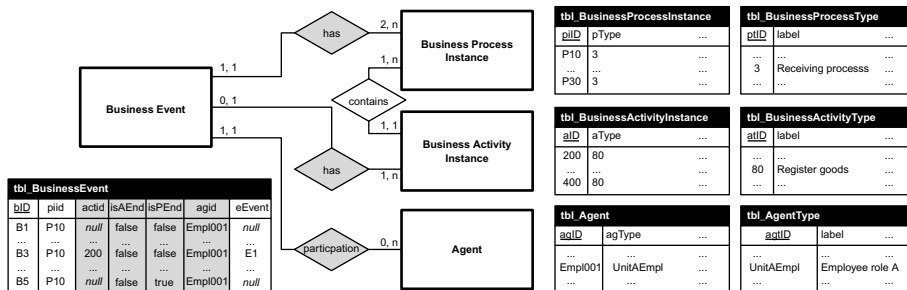

Figure 10. Data structure reflecting the process-relatedness of events on the operational level

Figure 10 is compatible with existing event data-exchange standards (see Becker *et al.*, 2012, for a review of event formats). Methods for reconstructing event data from operational databases when no event logs or explicit event data are initially available are also extant (Rodríguez *et al.*, 2012).

5.5 Economic reciprocity principle

The principle of economic reciprocity requires that event data capture changes in scarce means and reflect the “give-and-take” pattern in order to be considered an event-accounting database.

Consideration of economic reciprocity, a novel element in the structuring of event logs, is a central contribution of this paper. Incorporating the principles we have presented for structuring an event log enables decision makers to relate event occurrences to process states, facilitating analyses of process flow times and process execution paths. However, the economic implications of each process state cannot be disclosed by such event logs; more generally, it is not possible to reconstruct the economic rationale behind event occurrences.

Figures 11 and 12 show how economic reciprocity can be considered in designing an event-accounting database. The data structure, informed by the REA model (McCarthy, 1982) and the work of Gailly *et al.* (2008), implements the concept of transactions (Section 4). The black circles with numbers show which concepts of the data structure specification (upper part of the figures) correspond to which accounting (middle part of the figure) and to which BPM artefacts (lower part of the figure).

Figure 11 shows the data structure required to define plans and policies for anticipated occurrences of economic events and commitments. Economic commitments are promises to fulfill economic events in the future, and commitment types are abstract descriptions of such promises. Commitment types are specialized into increment and decrement commitment types, each of which can be part of a contract-type specification. A contract-type specification can, for example, be an empty order form (see the purchase order template in Figure 11). Commitment types can be fulfilled by various types of economic events.

Like commitments, economic events are differentiated according to their impact on economic resources. Increment and decrement types of economic events can be assigned to particular transaction types.

Transactions and contracts must have at least one increment and at least one decrement event/commitment type. For each contract type the transaction types that the contract type is expected to realize can be specified. Economic reciprocity is reflected both by transaction and by contract-type definitions since transactions and contracts reflect compensating changes in economic resources.

The specification of contract and transaction types may interact with process designs. Transaction types specify the event types that are expected to fulfil individual commitment types. To comply with the economic rationale implied by the contract and transaction type definitions, a process definition should contain all of these event types.

Figure 11 indicates how economic reciprocity can be reflected in process designs. The purchase order type shown in Figure 11 is comprised of two commitment types:

- (1) an increment commitment by a supplier to receive a good (order item); and
- (2) a decrement commitment by the purchasing organization to pay for the purchase.

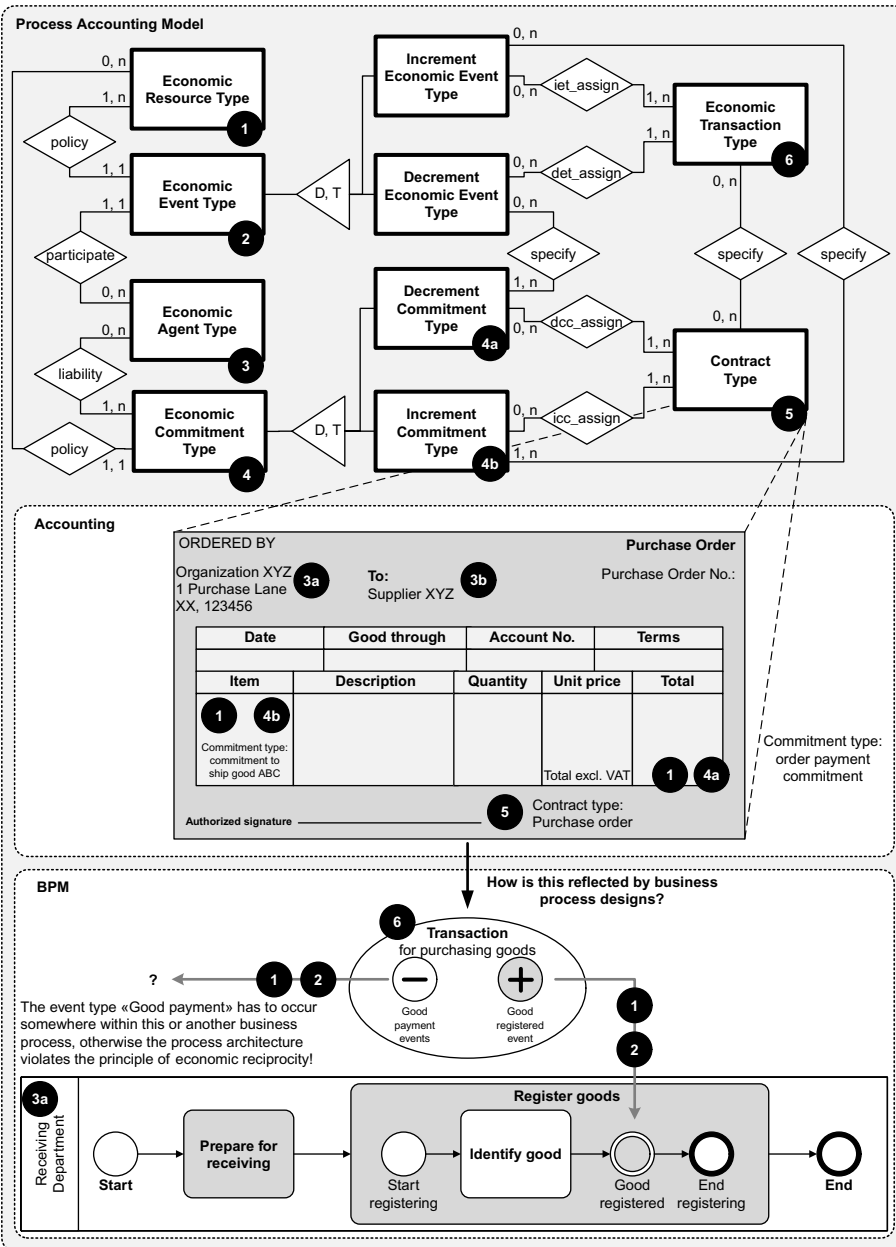
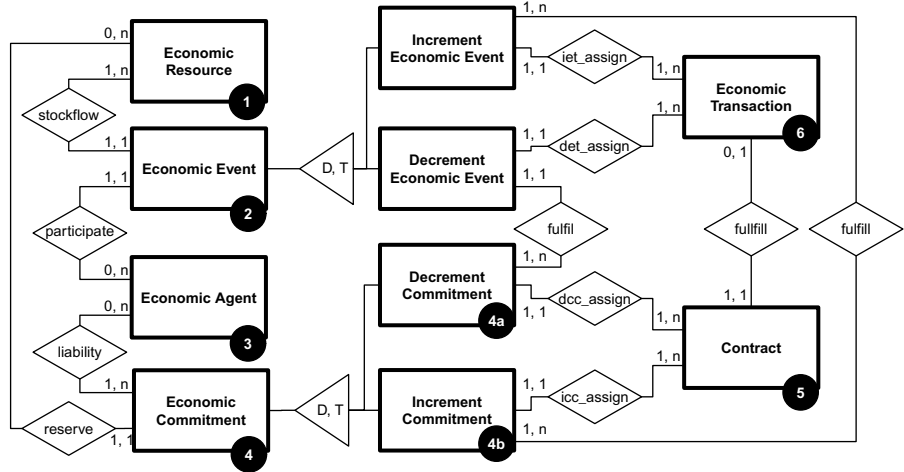

Figure 11.
Economic reciprocity
reflected on the policy
and planning levels

An acquisition transaction that requires a payment event (decrement) and a compensating good-receipt event (increment) must be realized to fulfil this contract. Process managers must ensure that the commitments implied by a contract (e.g. issuing an order) can be fulfilled by events that occur in business processes; that is, process



ORDERED BY: Organization XYZ, 1 Purchase Lane, XX, 123456 (3a)

To: Supplier Quality goods, Main road1, XX, 654321 (3b)

Purchase Order No.: T52115 (5)

Date	Good through	Account No.	Terms	
12/20/2012	27/02/2013		t/1, t/3, r/5	
Item	Unit price	Quantity	Unit price	Total
Good ABC-10	Special high performance	1.000 (ltr)	5.25 EUR/ltr	5.250,00 EUR
Good ABC-13s	glue Glue gun	1 (piece)	350.00 EUR	350,00 EUR
			Total excl. VAT	5.600,00 EUR

Authorized signature: [Signature] (1, 4a)

tbl_EconomicEvent				tbl_IncrementEconomicEvent							tbl_EconomicTransaction			tbl_EconomicTransactionType		
ecID	incEvt	decEvt	...	ieID	agID	duration	resource	quantity	value	fulfills	transaction	ttID	type	contract	ttID	description
...	E1	IE1	E1	Empl001	0	R10	1.000	5.250,00	IC1	T52115	T52115	tt50	Purchase transaction	

tbl_EconCommitment				tbl_IncrementEconomicCommitment						tbl_Resource			tbl_ResourceType		
ecID	incC	decC	...	icID	agID	resource	quantity	value	contract	riD	type	...	rtID	description	...
...	C1	IC1	IC1	SppQG	R10	1.000	5.250,00	R10	r10	...	r10	Good ABC 10 ...	
...	C2	IC2	IC2	SppQG	R13s	1	350,00	R13s	r13s	...	r13s	Good ABC 13s ...	

tbl_DecrementEconomicCommitment				tbl_Contract			tbl_ContractType				
dcID	agID	resource	quantity	value	Contract	ctID	type	...	ctID	description	...
...	DC1	Dpt_Pur1	R1c	1	5.600,00	C525115	ct50	...	ct50	Purchase order	...

Figure 12. Economic reciprocity reflected on the operational level

managers must plan occurrences of economic events that fulfil the commitments implied by contracts. In the example, the receipt of a good occurs in the context of an inbound logistics process, while the payment for goods is executed in a separate payment process. Current process modelling approaches have only limited means to support validations of process architectures regarding the satisfaction of economic

reciprocity. Currently, only simple Input/Output relationships are reflected in process models (Figure 6) without considering timing elements (e.g. payments for a purchase could be made before or after receiving a good). As a result, economic interdependencies within and between processes are barely visible at design time. However, Sonnenberg *et al.* (2011) and Müller-Wickop *et al.* (2013) outlined how economic reciprocity could be considered in more detail in process models.

Figure 12 presents a data structure for event-accounting databases on the operational level. This data structure is intended to account for what has occurred or is currently occurring, including the contracts to which an organization has committed. The data structure is a mirror image of Figure 11, but the cardinality constraints between events and transactions and between commitments and contracts differ. Moreover, a contract instance can be fulfilled only by exactly one transaction instance.

Transactions are “event containers” that accumulate events over time. Only if all commitments have been fulfilled by the events of a transaction (as specified in a contract) can a transaction be said to be complete or in balance. In the purchase order example, it might be that the goods received are paid through multiple payment events, all of which refer to the same transaction instance. As long as the payments that are conducted do not match the committed payment amount specified in the purchase order, the purchase transaction is imbalanced. The example in Figure 12 assumes that only one of the goods ordered, “Good ABC 10”, has been received and that the supplier has not yet issued an invoice. In this case the purchase transaction instance is imbalanced, which represents a liability that in traditional accounting is usually documented in an accounts payable account. In Figure 12 the amount of accounts payable (obligation to pay for a purchase) is €5,250, the monetary value of “Good ABC 10,” since no decrement economic event (cash disbursement) has been registered for the related transaction yet. Moreover, according to the event log, the organization still expects the delivery of “Good ABC 13s,” so the commitment the supplier made is not yet fulfilled. Future occurrences of the receipt of “Good ABC 13s” and cash payments that are related to the contract instance “C52115” will be added to the event set of transaction “T52115.”

We should note how resource uses (as opposed to resource consumptions) are treated in the PAM. Events that denote the use of resources, such as the use of human work force measured in terms of working hours or the use of machinery measured in terms of machine hours, are treated as implicit economic events that have a duration (Section 4.3). These events are implicit because they are usually not explicitly defined as part of a transaction, so implementations of the PAM must ensure that, for each business activity execution, these decrement economic events are captured by default in the accounting database and are assigned to a transaction instance. In the example in Figure 12, that decrement events for the activities “prepare for receiving” and “identify good” must be classified and registered as economic events that reduce the availability of the workforce (measured in terms of working hours) for the time the activities are executed. Since the occurrences of these events happen in the context of a transaction (here “T52115”), they must be assigned to this transaction as decrement economic events. The duration and frequency of resource-use events can act as a basis on which to allocate the indirect costs incurred by resource use to business activities according to the principles of time-driven activity-based costing (TD-ABC) (Kaplan and Anderson, 2004).

The next section describes exemplary cases for which the PAM can be readily applied.

6. Exemplary cases of the use of the PAM

6.1 Double-entry bookkeeping – the process-oriented way

We introduced a data structure that allows accounting conclusions to be drawn directly from an event log of a PAIS. The events-accounting paradigm that is incorporated into this data structure is fundamentally different from the widely applied double-entry bookkeeping paradigm in that it accounts only for resource flows that have actually happened in the context of a process execution. Events accounting relates these resource flows to the events that caused them and not to an account structure as occurs in the double-entry bookkeeping scheme, which is unrelated to any notion of business process.

The process orientation of the events-accounting approach notwithstanding, it would be beneficial for the applicability and acceptance of the PAM in practice if the widely applied double-entry bookkeeping scheme could be supported by PAM anyway. Moreover, for reasons of compliance many companies are obliged or legally forced to apply the generally accepted accounting principles that require the application of double-entry bookkeeping. In fact, enabling double-entry bookkeeping based on an event record structured according to the PAM actually requires only a minor extension of the basic model. This extension is specified in an entity-relationship diagram in Figure 13 and illustrated by means of an example in Figure 14.

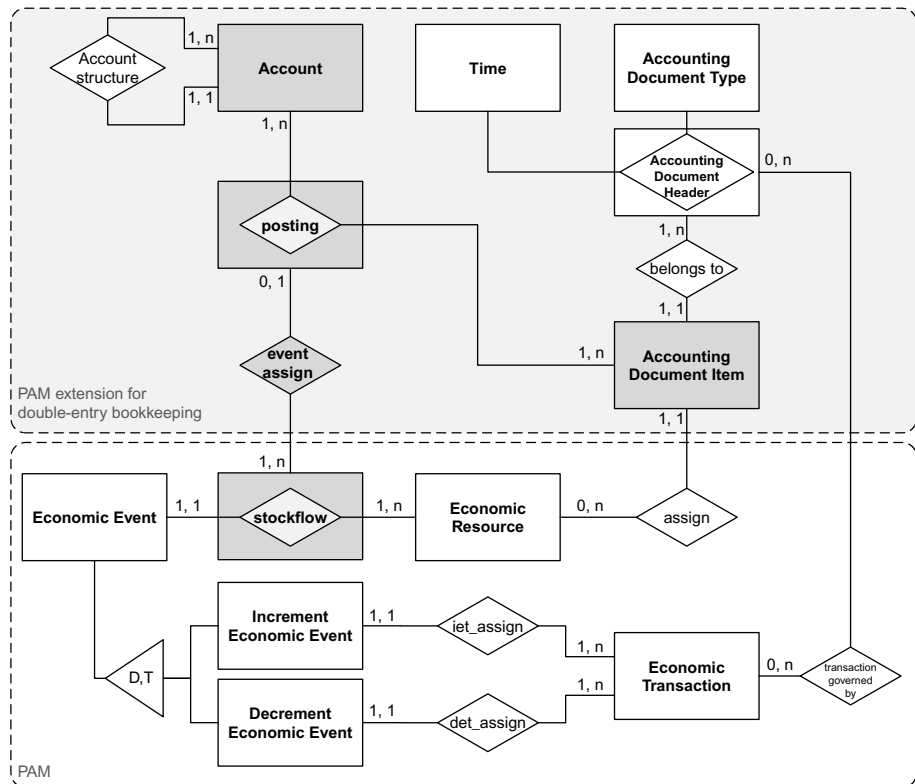
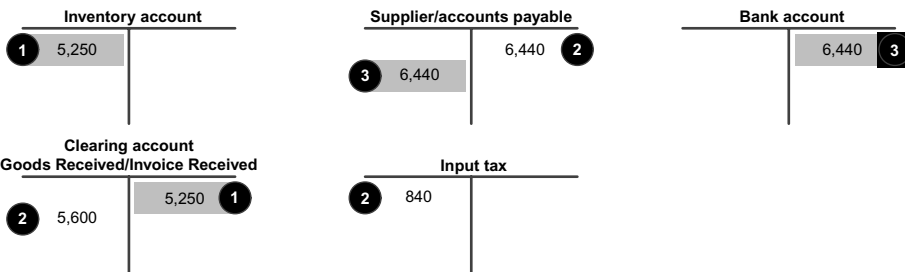
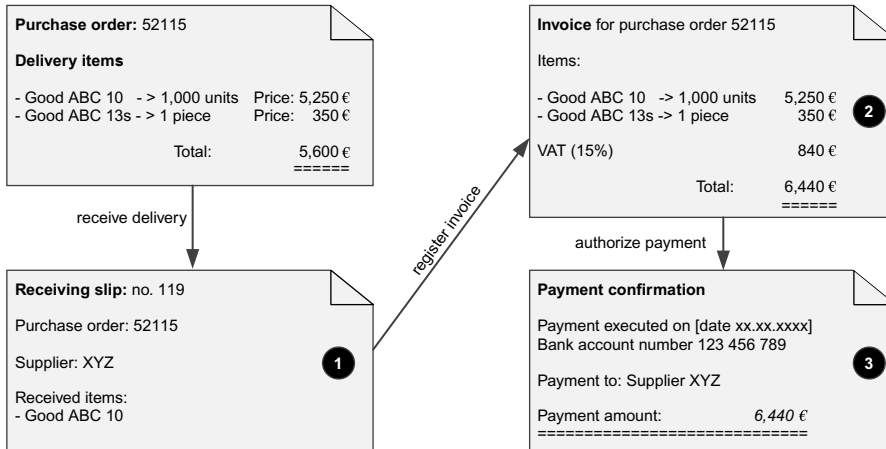

Figure 13.
Extension of the PAM for
double-entry bookkeeping



tbl_IncrementEconomicEvent						
idID	agid	duration	resource	quantity	value	...
...
E1	Empl001	0	R10	1.000	5.250,00	1
...

tbl_Account		
AccID	description	...
5	Inventory	...
6	GR/IR	...
7	Supplier/AP	...
8	Input Tax	...
9	Bank	...

tbl_posting					
AccID	DocItemID	event_ID	debit	credit	...
5	1	E1	5,250	null	1
6	1	E1	null	5,250	1
6	4	null	5,600	null	2
8	3	null	840	null	2
7	5	null	null	6,440	2
7	5	D1	6,440	null	3
9	5	D1	null	6,440	3
...

tbl_DecrementEconomicEvent						
delID	agid	duration	resource	quantity	value	...
...
D1	Empl009	0	R1c	1	6.440,00	3
...

Figure 14.
Account postings
in a purchasing
transaction based on the
extended PAM

Figure 13 contains an excerpt of the PAM that shows increment and decrement event types paired in duality (lower part of Figure 13) and the entity types that are used for double-entry bookkeeping (upper part of Figure 13, Scheer, 1994, pp. 611) but are not part of the PAM core. The central entities in traditional accounting are the accounting documents, such as customer invoices, supplier invoices, payment receipts, material issue slips, and receiving slips, that are used to document economic transactions. Another central entity is the Account, which records the debits and credits implied by an economic transaction. Account balances are updated based on postings, which relate an accounting document item (e.g. a line item in a supplier invoice) with one or more accounts. That is, each receipt of an accounting document implies an update of one or more account balances, regardless of whether a resource flow has occurred or not.

However, a posting can also reflect an actual resource flow, such as a cash inflow. It is at this point that the PAM interfaces with double-entry bookkeeping, as each resource flow (stockflow) implies a posting to one or more accounts. In technical terms the table posting has a foreign-key attribute that refers to the economic event instance recorded in the event log. Process managers and accountants refer to the posting table to see what resource flows have been caused by what process instance. Account postings that do not reflect resource flows (e.g. the postings related to registering an invoice) have no reference to an economic event, but they could relate to business events (i.e. an event that denotes an individual posting). Our data structure allows such information to be maintained by simply adding a foreign key "business_event_id" to the table posting.

To demonstrate how the specified interface between the PAM and double-entry bookkeeping works in practice, consider the example in Figure 14, which extends the example presented in Figure 11. In a goods-receipt process a delivery of 1,000 units of "Good ABC 10" arrives and is associated with purchase order "no. 52115". On delivery a receiving slip is created, triggering the assignment (posting) of the received item, "Good ABC 10," to the balance sheet account, "Inventory," and to a profit and loss account, "Goods received/invoice received." This posting is associated with an economic event that denotes a stock increase for "Good ABC 10." In the next step, a supplier invoice indicating an outstanding payment of €6,440 (€5,600 for the ordered goods plus €840 taxes) is received. When the invoice is registered, no further resources flows (stockflows) related to the purchase transaction have been registered for purchase order "no. 52115," so invoice-related postings have no reference to an economic event. Accounts "Supplier/accounts payable," "Input tax," and "Goods received/invoice received" are affected by the invoice registration. The "goods received/invoice received" account serves as a clearing account that indicates whether invoices have been issued, even when no goods were received or goods were received without an invoice (Scheer, 1994). It is easy to calculate that the clearing account has a balance of €350 since not all goods ordered have been received yet.

After the invoice is received, the accounting department settles it through a payment from a bank account. The "Supplier/accounts payable" account and the "Bank" account are affected by posting the payment. Since the payment involves a stockflow of the "cash" resource, the posting refers to a decrement economic event.

Eventually, account postings or financial statement line items (FSLI) can be traced back to the process instances and events that caused them, which is not possible in traditional accounting systems that are considered process-unaware (McCarthy, 1982). In particular, the ability to trace account updates to processes and events can be used to support process auditing and process modelling tasks. These use cases are discussed in the next section.

6.2 Sensing economic reciprocity in business process structures

The PAM can also be used to verify whether a particular process structure adheres to the "give and take" pattern. Current approaches to process evaluations are limited to only "one-way" economic assessments, which are limited to evaluating processes with regard to flow times, quality, or costs. However, any business process is executed (efficiently) for a reason, and this rationale usually materializes in an increase in economic resources that balances the negative effect of process costs or long flow times. The "one-way" process assessments only arbitrarily reflect economic reciprocity, so a systematic approach to evaluating the economic feasibility and economic consistency of a business process is missing.

The PAM may well inform such a systematic analysis of process structures regarding the consideration of economic reciprocity. In particular, the PAM can support process modelling and process simulation, process auditing, and process mining.

According to the PAM, a process model is economically consistent if it fulfils at least part of an economic transaction, and if the process model is partially consistent, it specifies an interface to another process that fulfils the other part of the economic transaction. A straightforward way to determine whether a process model complies with the economic reciprocity principle is to identify the increment and decrement types of economic events in a process model and assign them to transaction types. If no economic event type can be identified, the business process in question fulfils no business purpose and does not contribute to any economic transaction at all. In such cases, the business process specification should be extended to contain at least one economic event.

Figure 15 illustrates the notion of economic consistency for the purchase process discussed above. In particular, Figure 15 exemplifies how this consistency criteria can inform the specification of a PAM-compliant simulation model. The simulation model has been specified using the coloured petri net (CPN) formalism (Jensen and Kristensen, 2009)[1].

Figure 15 shows the “give-and-take” pattern of the PAM by specifying increment and decrement types of economic events (transitions) that contain sub-nets or sub-processes – CPNs support the modelling of hierarchical petri nets – that contain the precise logic for receiving and paying for a good. The increment transition has an input place that contains the type of resources – in this case, purchased goods – that are flowing in, and the decrement transition is connected to an output place that contains the outflowing resources (cash). Both transitions are connected to a resource place that represents the organization’s overall resource stock, which is updated on every inflow and outflow of resources. The resource stock also supports the execution of the sub-processes. For example, a goods received event can be realized only after an employee (human resource) physically checks the delivery and creates a receiving slip (These details are hidden in a sub-net).

The PAM also specifies that each economic event fulfils an economic commitment. Accordingly, increment and decrement transitions in the purchasing process are

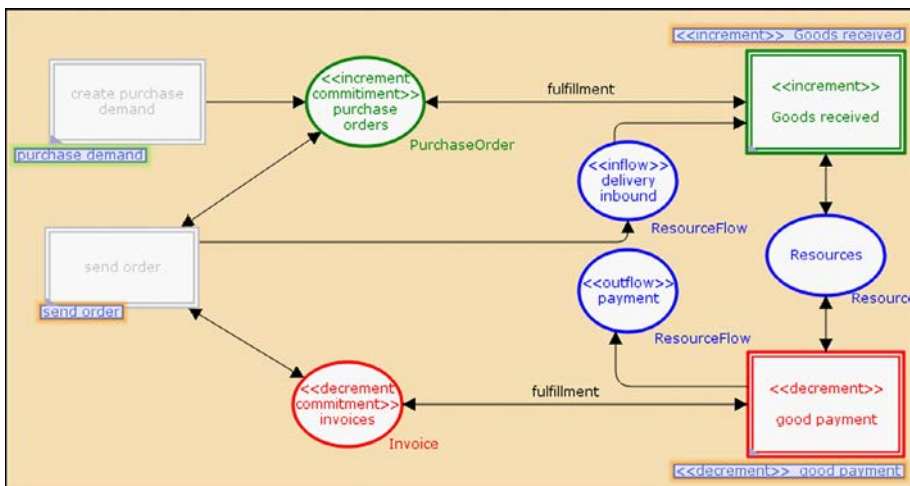

Figure 15.
High-level CPN
for a purchasing
business process

enabled only if there are corresponding increment and decrement commitment tokens in the input places (e.g. for a delivery, a purchase order must exist; for a goods payment, an invoice must exist). The movements between increment/decrement commitment places and increment/decrement transitions are bi-directional, reflecting that each firing of a transition consumes (i.e. fulfils) a commitment (partially or fully). In case of a partial fulfilment, the commitment places are populated with updated commitment tokens.

The two transitions in the example illustrated in Figure 15 initiate and create parameters for the simulation and do not correspond to any PAM construct. The transition “create purchase demand” creates purchase order tokens (e.g. with a random time delay and a random order volume). The “send order” transition reflects the policy that requires a supplier to send goods only if a purchase order exists. This transition makes it possible to specify delivery policies in a subnet (e.g. each purchase order item in a purchase order is delivered individually with a specified time delay).

The simulation model in Figure 15 is considered fully consistent in terms of the PAM, as it contains both increment and decrement economic events (or the sub-processes that cause these events to occur). Simulation models frequently neglect economic reciprocity; a naïve approach to modelling the purchase process would be to specify in detail the goods-receiving process only. Such a simplified process model would allow the time it takes to receive products, the number of quality goods received, and the cost of resources involved in the receiving process to be analysed, while the interdependencies among the demand for goods, the terms of delivery, and the dynamics of the overall stocks of resources would remain hidden. For example, decision makers would want to ask what is the demand for cash in order to meet the demand for goods in a specified period and what payment policies are feasible given a specified demand pattern.

The model depicted in Figure 15 could be extended by modelling production processes (transformation transactions) that require resources from an organization’s resource stock. Eventually, the simulation model could be extended further by considering the sales processes (exchange transactions) that generate inflows of financial resources and require outflows of resources produced. Then the simulation model would reflect a complete accounting cycle that represents the entrepreneurial script of an organization under study.

The PAM could also be used to annotate business process models that have been defined using semi-formal modelling languages like the BPMN. Semi-formal process models support business managers more than they support IT managers, as these models abstract from technical details and focus on representing business-relevant information. Müller-Wickop *et al.* (2013) proposed an extension of the BPMN (OMG-BPMN, 2012) to represent the financial resource flows in process models (Figure 16). This extension should particularly support auditors when they assess how well an organization’s business processes comply with financial reporting and regulatory compliance standards. For process auditors, key points of interest in a process audit are to identify the activities that have financial impact and to “know if 80 per cent or just 20 per cent of the overall volume are processed by a certain process” (Müller-Wickop *et al.*, 2013, p. 6). The proposed BPMN extension shown in Figure 16 helps auditors to identify activities that affect line items in financial statements (account postings) and to disclose the magnitude of an activity’s financial impact.

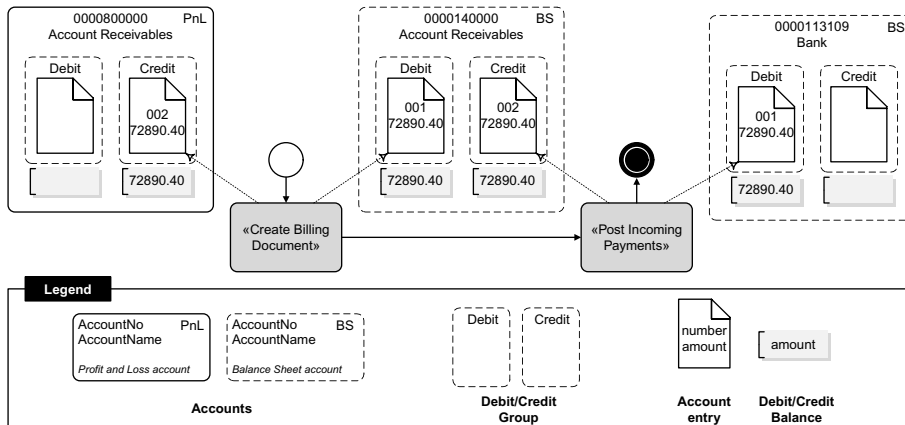

Figure 16. Representation of account postings in process models

Source: Taken from Müller-Wickop *et al.* (2013, p. 9)

A PAM-compliant event log can serve as an information infrastructure that can provide the data for populating the data fields of the notational elements. As shown in Section 6.1, the PAM structure readily supports this kind of modelling language extension for the purpose of process auditing.

Another use case for PAM relates to the auditing problem of showing that actual process instances comply with an intended process behaviour. Auditors may not have access to a process model that specifies this intended behaviour and be forced to reconstruct a process structure based on existing event records by means of (financial) process mining (Gehrke and Müller-Wickop, 2010; van der Aalst, 2011). The PAM supports process-mining tasks, as it records business and economic events in their process context. In particular, the PAM event record stores data about the activity and process instances that are needed in order to reconstruct process structures from event logs (van der Aalst, 2011). Moreover, the PAM accounts for economic transactions, which should allow the mining of financial resource flows within and between business processes.

6.3 Business activity monitoring 2.0 – leveraging event log-data for real-time accounting

Finally, the PAM can be used in the context of real-time business activity monitoring and real-time accounting. Having accounting information like current inventory levels or customer demands available in a timely manner enables companies to innovate current business models. For example, vom Brocke *et al.* (2014) identified four cases driven by in-memory computing that significantly rely on a timely provision of accounting data:

- (1) dynamic pricing (requiring data on current inventory levels, demand, individual purchase history, other customers' purchases, age of perishable goods);
- (2) *ad hoc* couponing (requiring data on the current shopping basket, individual purchase history, other customers' purchases);
- (3) real-time-on-the-shelf-availability management (requiring data on resource flows at a point of sale); and
- (4) Intraday forecasting and replenishment (requiring data on resource flows between stores).

All of these cases depend on the timely availability of analytics information on accounting data. If these accounting data relate to economic resource flows only, they can be stored in a central PAM-compliant event record. The event record structure implied by the PAM supports the provision of relevant process-oriented accounting data from a single source without the need to query many data sources, as would usually be the case in the context of ERP systems (van der Aalst *et al.*, 2010). In terms of business activity monitoring, the PAM may contribute to the timely delivery of analytics information by reducing the analysis latency (Figure 17). Analysis latency describes the time between the storage of event data and the subsequent transformation of the event data for analysis purposes (zur Mühlen and Shapiro, 2010). By reducing the time needed for event-data transformations in combination with the potential of in-memory computing, the PAM contributes to reducing the overall reaction time required to make timely business-process-related decisions, and, thus supports near-real time accounting scenarios.

We refer to the use case of keeping a PAM-compliant event log in an in-memory database as business activity monitoring 2.0. This case represents an evolution of current business-activity monitoring approaches (zur Mühlen and Shapiro, 2010) since it leverages not only data on business events but also data on economic events for the purpose of monitoring and controlling business processes in real time.

7. Conclusion

This paper conceptualizes the intersection between BPM and accounting, the main result of which is a PAM. This PAM proposes a generalized data structure for event logs of PAIS that allows for process-oriented accounting and accounting-oriented process management (or value-oriented process management). The design of the PAM

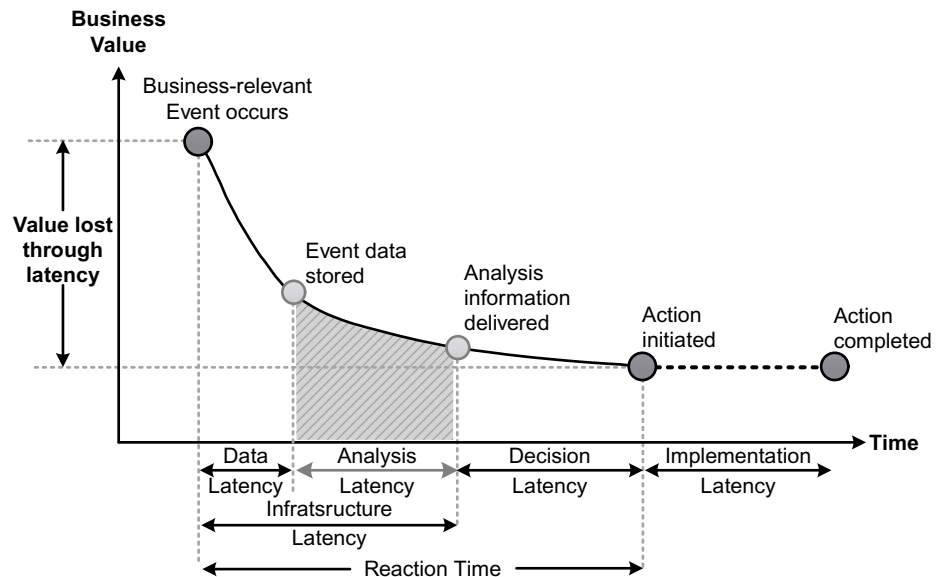

Figure 17. Anticipated impact of the PAM on the analysis latency in the context of business activity monitoring

Source: Adapted from zur Mühlen and Shapiro (2010, p. 147)

is grounded in the “events” approach to accounting theory (Sorter, 1969). While we designed the PAM to integrate with PAIS, it also integrates with traditional double-entry bookkeeping AIS.

The PAM is novel in two-ways: it informs the creation of process-event logs that allow process managers and accountants to relate economic impacts to individual process states, and it explicitly accounts for economic reciprocity, thereby explicating the economic rationale that underlies individual process architectures.

Our contribution should be viewed in light of some limitations. First, the PAM is the result of our design process, which is influenced by our own views and abstractions. We based our design in extant literature, but other researchers may have arrived at other design solutions. Second, we evaluated the consistency of artefact design and its applicability (EVAL2 and EVAL3), but additional evaluations should be conducted to gain further insights into the usefulness of the PAM.

Future work may particularly focus on how process managers and accountants can be supported in the identification and classification of relevant business events and economic events. This issue relates to process modelling support and the re-use of process models for accounting purposes. In particular, current process modelling formalisms should be augmented with constructs that enable process designers, accountants, and auditors to describe the economic interdependencies among processes (First attempts in this regard have been proposed by Sonnenberg *et al.*, 2011 and Müller-Wickop *et al.*, 2013). A PAM-complaint event log could support such modelling-language extensions by populating process models with relevant accounting data in order to make it feasible to validate the economic feasibility of whole process architectures at design time. Another promising avenue for future research is to derive process modelling patterns that are consistent with the design principles of PAM and that can be used to construct process-simulation models (similar to the work of Laurier and Poels, 2013) or to evaluate process models with regard to their “economic consistency.”

Note

1. The software CPN Tools was used to model the purchasing business process (see www.cpn-tools.org).

References

- AICPA (1970), “Accounting principles board”, Statement No. 4, para. 9, American Institute of Certified Public Accountants, New York, NY.
- Bragranoff, N.A., Simkin, M.G. and Norman, C.S. (2012), *Core Concepts of Accounting Information Systems*, 11th ed., Wiley, New York, NY.
- Balasubramanian, S. and Gupta, M. (2005), “Structural metrics for goal based business process design and evaluation”, *Business Process Management Journal*, Vol. 11 No. 6, pp. 680-694.
- Becker, J., Matzner, M., Müller, O. and Walter, M. (2012), “A review of event formats as enablers of event-driven BPM”, *Business Process Management WorkShops*, Springer, Berlin, pp. 433-445.
- Buhl, H.U., Röglinger, M., Stöckl, S. and Braunwarth, K.S. (2011), “Value orientation in process management – research gap and contribution to economically well-founded decisions in process management”, *Business & Information Systems Engineering*, Vol. 3 No. 3, pp. 163-172.
- Chen, P.P. (1976), “The entity-relationship model: towards a unified view of data”, *ACM Transactions on Database Systems*, Vol. 1 No. 1, pp. 9-36.

- Davenport, T.H. (1993), *Process Innovation: Reengineering Work Through Information Technology*, Harvard Business School Press, Boston, MA.
- Decker, G., Grosskopf, A. and Barros, A.P. (2007), "A graphical notation for modelling events in business processes", *Proceedings of the 11th International Conference on Enterprise Distributed Object Computing, IEEE Computer Society Conference Publishing Services*, pp. 27-36.
- Denna, E.L., Cherrington, J.O., Andros, D.P. and Sawyer-Hollander, A. (1993), *Event-Driven Business Solutions: Today's Revolution in Business and Information Technology*, Burr Ridge, Irwin, IL.
- Dumas, M., van der Aalst, W.M.P. and ter Hofstede, A.H.M. (2005), *Process-Aware Information Systems*, Wiley, Chichester.
- Gailly, F., Laurier, W. and Poels, G. (2008), "Positioning and formalizing the REA enterprise ontology", *Journal of Information Systems*, Vol. 22 No. 2, pp. 219-248.
- Geerts, G.L. and McCarthy, W.E. (1999), "An accounting object infrastructure for knowledge-based enterprise models", *IEEE Intelligent Systems*, Vol. 14 No. 4, pp. 89-94.
- Geerts, G.L. and McCarthy, W.E. (2002), "An ontological analysis of the economic primitives of the extended REA enterprise information architecture", *International Journal of Accounting Information Systems*, Vol. 3 No. 1, pp. 1-16.
- Geerts, G.L. and McCarthy, W.E. (2006), "Policy-level specification in REA enterprise information systems", *Journal of Information Systems*, Vol. 20 No. 2, pp. 37-63.
- Gehrke, N. and Müller-Wickop, N. (2010), "Basic principles of financial process mining: a journey through financial data in accounting information systems", *Proceedings of the Sixteenth Americas Conference on Information Systems (AMCIS 2010)*, Lima, Peru.
- Goetz, B.E. (1939), "What's wrong with accounting?", *Advanced Management*, Vol. 4 No. 5, pp. 151-157.
- Guizzardi, G. and Wagner, G. (2005), "Some applications of a unified foundational ontology in business modeling", in Rosemann, M. and Green, P. (Eds), *Ontologies and Business Systems Analysis*, IDEA Publisher, Hershey, PA, pp. 345-367.
- Hammer, M. (1993), *Reengineering the Corporation: A Manifesto for Business Revolution*, Harper Business, New York, NY.
- Harmon, P. (2011), *Activity-Based Costing*, available at: www.bptrends.com/-/deliver_file.cfm?fileType=publication&fileName=advisor20110329%2Epdf (accessed 10 December 2012).
- Hevner, A.R., March, S.T., Park, J. and Ram, S. (2004), "Design science in information systems", *MIS Quarterly*, Vol. 28 No. 1, pp. 75-105.
- Janiesch, C., Matzner, M. and Müller, O. (2012), "Beyond process monitoring: a proof-of-concept of event-driven business activity management", *Business Process Management Journal*, Vol. 18 No. 4, pp. 625-643.
- Jensen, K. and Kristensen, L.M. (2009), *Coloured Petri Nets*, Springer, Berlin.
- Johnson, O. (1970), "Toward an 'events' theory of accounting", *The Accounting Review*, Vol. 45 No. 4, pp. 641-653.
- Kaplan, R.S. and Anderson, S.R. (2004), "Time-driven activity-based costing", *Harvard Business Review*, Vol. 82 No. 11, pp. 131-138.
- Klamm, B.K. and Weidenmier, M.L. (2004), "Linking business processes and transaction cycles", *Journal of Information Systems*, Vol. 18 No. 2, pp. 113-125.
- Laurier, W. and Poels, G. (2013), "Invariant conditions in value system simulation models", *Decision Support Systems*, available at: <http://dx.doi.org/10.1016/j.dss.2013.06.009>

- Luckham, D.C. (2002), *The Power of Events*, Addison-Wesley, Boston, MA.
- McCarthy, W.E. (1982), "The REA accounting model: a generalized framework for accounting systems in a shared data environment", *The Accounting Review*, Vol. 57 No. 3, pp. 554-578.
- March, T.S. and Smith, G. (1995), "Design and natural science research on information technology", *Decision Support Systems*, Vol. 15 No. 4, pp. 251-266.
- Mauldin, E.G. and Ruchala, L.V. (1999), "Towards a meta-theory of accounting information systems", *Accounting, Organizations and Society*, Vol. 24 No. 4, pp. 317-331.
- Melão, N. and Pidd, M. (2000), "A conceptual framework for understanding business processes and business process modeling", *Information Systems Journal*, Vol. 10 No. 2, pp. 105-129.
- Müller-Wickop, N., Schultz, M. and Nüttgens, M. (2013), "Modeling concepts for process audits – an empirically grounded extension of BPMN", *Proceedings of the 21st European Conference on Information Systems (ECIS 2013) in Utrecht, The Netherlands*.
- O'Leary, D.E. (2004), "On the relationship between REA and SAP", *International Journal of Accounting Information Systems*, Vol. 5 No. 1, pp. 65-81.
- OMG-BPMN (2012), *Business Process Modeling Notation (BPMN) Information*, available at: www.omg.org/spec/BPMN/2.0/PDF (accessed 1 December 2012).
- OMG-UML (2012), "Object management group – UML", available at: www.uml.org/ (accessed 1 December 2012).
- Peffers, K., Tuunanen, T., Rothenberger, M.A. and Chatterjee, S. (2007), "A design science research methodology for information systems research", *Journal of Management Information Systems*, Vol. 24 No. 3, pp. 45-77.
- Ramsay, J. (2005), "The real meaning of value in trading relationships", *International Journal of Operations & Production Management*, Vol. 25 No. 6, pp. 549-565.
- Riahi-Belkaoui, A. (2004), *Accounting Theory*, Cengage Learning EMEA, Stamford, CT.
- Riebel, P. (1994), "Core features of the 'Einzelkosten-und Deckungsbeitragsrechnung'", *European Accounting Review*, Vol. 3 No. 3, pp. 515-546.
- Rodríguez, C., Engel, R., Kostoska, G., Daniel, F., Casati, F. and Aimar, M. (2012), "Eventifier: extracting process execution logs from operational databases", *Proceedings of the Demonstration Track of the 10th International Conference on Business Process Management (BPM 2012), Tallinn, Estonia*.
- Scheer, A.W. (1994), *Business Process Engineering – Reference Models for Industrial Companies*, Springer, Berlin.
- Schmalenbach, E. (1948), *Pretiale Wirtschaftslenkung: Pretiale Lenkung des Betriebes*, Vol. 2, W. Dorn, Bremen-Horn.
- Schrader, W.J. (1962), "An inductive approach to accounting theory", *The Accounting Review*, Vol. 37 No. 4, pp. 645-649.
- Sonnenberg, C. and vom Brocke, J. (2012), "Evaluations in the science of the artificial – reconsidering the build-evaluate pattern in design science research", *Proceedings of the 7th International Conference on Design Science Research in Information Systems: Advances in Theory and Practice (DESRIST 2012)*, Springer, Berlin, pp. 381-397.
- Sonnenberg, C., Huemer, C., Hofreiter, B., Mayrhofer, C. and Braccini, A.M. (2011), "The REA – DSL: a domain specific modeling language for business models", *Proceedings of the 23rd International Conference on Advanced Information Systems Engineering (CAiSE 2012), London, UK*, Springer, Berlin, pp. 252-266.
- Sorter, G.H. (1969), "An 'events' approach to basic accounting theory", *The Accounting Review*, Vol. 44 No. 1, pp. 12-19.

- van der Aalst, W.M.P. (2011), *Process Mining: Discovery, Conformance and Enhancement of Business Processes*, Springer, Berlin.
- van der Aalst, W.M.P. and Weijters, A.J.M.M. (2005), "Process mining", in Dumas, M., van der Aalst, W.M.P. and ter Hofstede, A.H.M. (Eds), *Process-Aware Information Systems*, Wiley, Chichester, pp. 235-255.
- van der Aalst, W.M.P., van Hee, K.M., van Werf, J.M. and Verdonk, M. (2010), "Auditing 2.0: using process mining to support tomorrow's auditor", *Computer*, Vol. 43 No. 3, pp. 90-93.
- Venable, J., Pries-Heje, J. and Baskerville, R. (2012), "A comprehensive framework for evaluation in design science research", *Proceedings of the 7th International Conference on Design Science Research in Information Systems: Advances in Theory and Practice (DESRIST 2012)*, Springer, Berlin, pp. 423-438.
- vom Brocke, J. (2007), "Service portfolio measurement: evaluating financial performance of service-oriented business processes", *International Journal of Web Services Research*, Vol. 4 No. 2, pp. 1-32.
- vom Brocke, J., Recker, J. and Mendling, J. (2010), "Value-oriented process modeling: integrating financial perspectives into business process re-design", *Business Process Management Journal*, Vol. 16 No. 2, pp. 333-356.
- vom Brocke, J., Sonnenberg, C. and Baumöel, U. (2011), "Linking accounting and process-aware information systems – towards a generalized information model for process-oriented accounting", *Proceedings of the 19th European Conference on Information Systems (ECIS 2011)*, Helsinki, Finland.
- vom Brocke, J., Sonnenberg, C. and Simons, A. (2009), "Value-oriented information systems design: the concept of potentials modeling and its application to service-oriented architectures", *Business & Information Systems Engineering*, Vol. 1 No. 3, pp. 223-233.
- vom Brocke, J., Debortoli, S., Müller, O. and Reuter, N. (2014), "How in-memory technology can create business value: insights from the Hilti case", *Communications of the AIS*, Vol. 34.
- Wynn, M.T., Low, W.Z. and Nauta, W. (2013), "A framework for cost-aware process management: generation of accurate and timely management accounting cost reports", *Proceedings of Conferences in Research and Practice in Information Technology (CRPIT)*, Australian Computer Society, Sydney.
- Yen, V.C. (2009), "An integrated model for business process measurement", *Business Process Management Journal*, Vol. 15 No. 6, pp. 865-875.
- zur Mühlen, M. and Shapiro, R. (2010), "Business process analytics", in vom Brocke, J. and Rosemann, M. (Eds), *Handbook on Business Process Management: Strategic Alignment, Governance, People and Culture*, Springer, Berlin, pp. 137-157.

Corresponding author

Christian Sonnenberg can be contacted at: christian.sonnenberg@uni.li